



# INSTALLATION INSTRUCTIONS

## ELECTRIC FUEL PUMPS - Mr. Gasket Part No. 95P, 105P and 130P FUEL PRESSURE REGULATOR - Mr. Gasket Part No. 2015

**READ ALL INSTRUCTIONS CAREFULLY BEFORE BEGINNING INSTALLATION. #95P AND #105P ARE NOT COMPATIBLE WITH ALCOHOL OR METHANOL FUELS AND ARE NOT FOR FUEL INJECTED SYSTEMS.**

### GENERAL INFORMATION

The Mr. Gasket Electric Fuel Pump **#95P** is a gravity feed vane/rotor type high volume low pressure pump designed for street applications. The operating fuel pressure is factory set at 7 PSI. Normally, a fuel pressure regulator is not necessary. We recommend a 3/8" I.D. hose with this fuel system. #95P free flows at 95 GPH and 65 GPH at 5 PSI.

The Mr. Gasket Electric Fuel Pump **#105P** is a gravity feed vane/rotor type high volume low pressure pump designed for strip applications. The operating fuel pressure is factory set at 12 PSI. This pump must be used with a fuel pressure regulator, which is included. We recommend a 3/8" I.D. hose with this fuel system. The fuel return line should be as large, or larger, than the fuel line between the fuel pump and the regulator. #105P free flows at 105 GPH and 70 GPH at 9 PSI.

The Mr. Gasket Electric Fuel Pump **#130P** is a gravity feed vane/rotor type high volume low pressure pump designed for race applications and is compatible with alcohol and methanol fuels. The operating fuel pressure is factory set at 12 PSI. This pump must be used with a fuel pressure regulator, which is NOT included. We recommend Mr. Gasket Part. No. #2015. We also recommend a 3/8" I.D. hose with this fuel system. The fuel return line should be as large, or larger, than the fuel line between the fuel pump and the regulator. #130P free flows at 130 GPH and 115 GPH at 9 PSI.

The Mr. Gasket Fuel Pressure Regulator **#2015** is a return-style fuel pressure regulator. The operating fuel pressure range is 4.5 – 9 PSI. The inlet/outlet size is 3/8" NPT. The fuel return line size should be 3/8" I.D. or larger or the regulator will not

regulate properly. Refer to Figure 2.

When installing the fuel pump fittings, use a fuel resistant thread sealant compound on the fitting threads. DO NOT use thread sealing tape or silicone based sealant. Do not over tighten fittings, as this could cause parts to crack, which may cause fuel leakage.

### MOUNTING PROCEDURE

#### Step 1

Mount the pump as close as possible to the fuel tank (at or below the level of the fuel tank pickup) in a well ventilated area. The pump should not be subjected to low ground clearance, road debris or chassis movement. Avoid exposing the pump and fuel lines to moving parts and hot surfaces, such as the exhaust system. **NOTE: Increasing distance between the pump and tank will decrease pump efficiency.**

#### Step 2

Using the pump mounting bracket as a template, drill two holes for 5/16" bolts. Insert the rubber gaskets between the housing for the motor and the mounting bracket. **NOTE: Using two 5/16" bolts, mount the pump in a vertical position with the motor on top to ensure against a potential fire hazard from pump flooding.**

#### Step 3

Connect fuel lines as shown in Figure 1 (A-no regulator or B-includes regulator). If your fuel system requires a fuel pressure regulator, proceed to the instructions with the fuel pressure regulator. **NOTE: Avoid unnecessary restrictions in hoses and undersized fittings or hoses. All fuel line connections should be leak proof.**

**FIGURE 1A  
MR. GASKET ELECTRIC FUEL PUMP #95P (DOES NOT INCLUDE REGULATOR)**

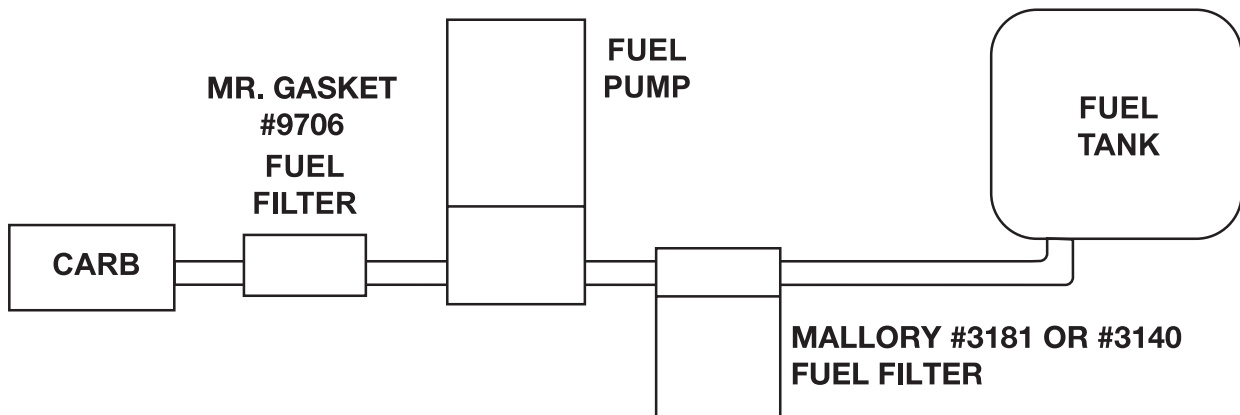

**FIGURE 1B**  
**MR. GASKET ELECTRIC FUEL PUMP #105P (INCLUDES REGULATOR)**  
**MR. GASKET ELECTRIC FUEL PUMP #130P (DOES NOT INCLUDE REGULATOR)**

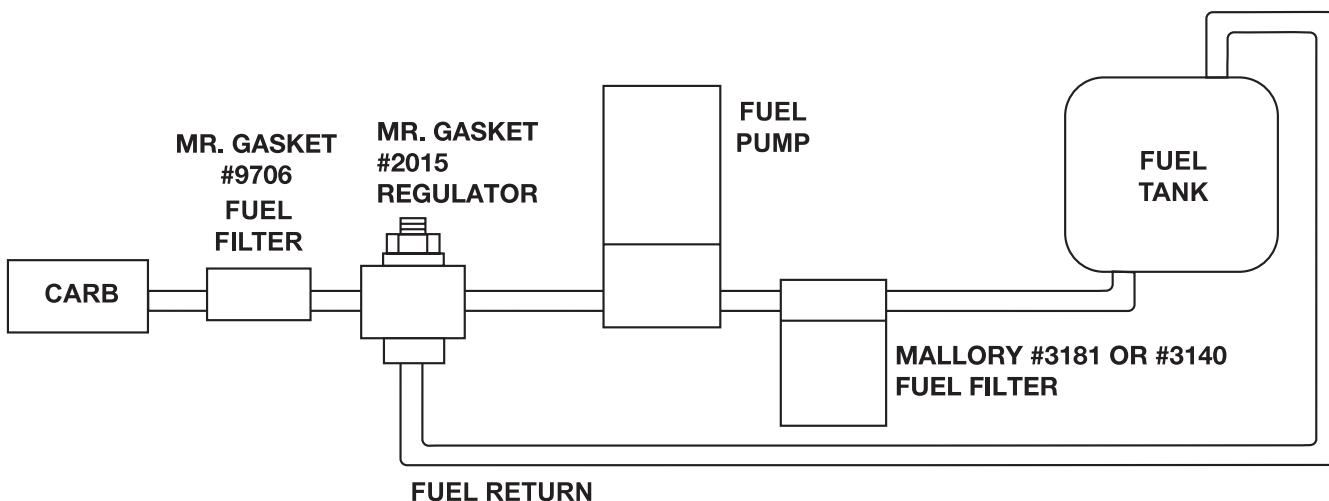

**Step 4**

If you choose to no longer use your mechanical fuel pump, make sure to disconnect the fuel lines, plug the ports and bypass the pump from the circuit. If you choose to remove your mechanical fuel pump, make sure to seal the opening with a metal cover and gasket. We recommend Mr. Gasket Part No. 1515, 1516, 1517, 9125G or 9126G depending on your application.

**FUEL PRESSURE ADJUSTMENT**

Depending on requirements, the regulator may need adjustment. To increase regulator pressure, turn adjustment screw clockwise; and turning the adjustment screw counter-clockwise will decrease pressure. **NOTE: Turning the adjustment screw all the way will cause carburetor flooding. Make sure to use a fuel pressure gauge when adjusting fuel pressure.**

**PRESSURE REGULATOR INSTALLATION**

**Step 1**

Mount the fuel pressure regulator as close as possible to the carburetor. **Note: Do not mount the regulator on or near exhaust manifolds. A bracket is provided for convenient mounting.**

**WIRING PROCEDURE**

Wiring the pump to an oil pressure switch will provide power only when the ignition switch is on and the engine is running. This will prevent the pump from running if your engine stalls. Use 14 gauge wire or larger. See Figure 3 or 4. We recommend Mr. Gasket Part No. 7872. **NOTE: Disconnect the battery ground cable before wiring the pump.**

**Step 2**

Attach the fuel line from the outlet side of the fuel pump to either side of the fuel pressure regulator. See Figure 1B above. All fuel line connections should be leak proof. The fuel return line should be as large, or larger, than the fuel line between the fuel pump and the regulator. See Figure 2 for size recommendations.

**FIGURE 2**  
**FUEL RETURN LINE SIZE RECOMMENDATIONS**

Fuel Return Line Length/Distance	GAL. PER HOUR (FREE FLOW)		
	1 to 99	100 to 129	130 to 199
16'-20'	1/2"	1/2"	5/8"
11'-15'	3/8"	1/2"	5/8"
6'-10'	3/8"	1/2"	1/2"
1'-5'	3/8"	1/2"	1/2"
	3/8" = 6AN	1/2" = 8AN	5/8" = 10AN

**FIGURE 3 - RECOMMENDED WIRING WITH RELAY**

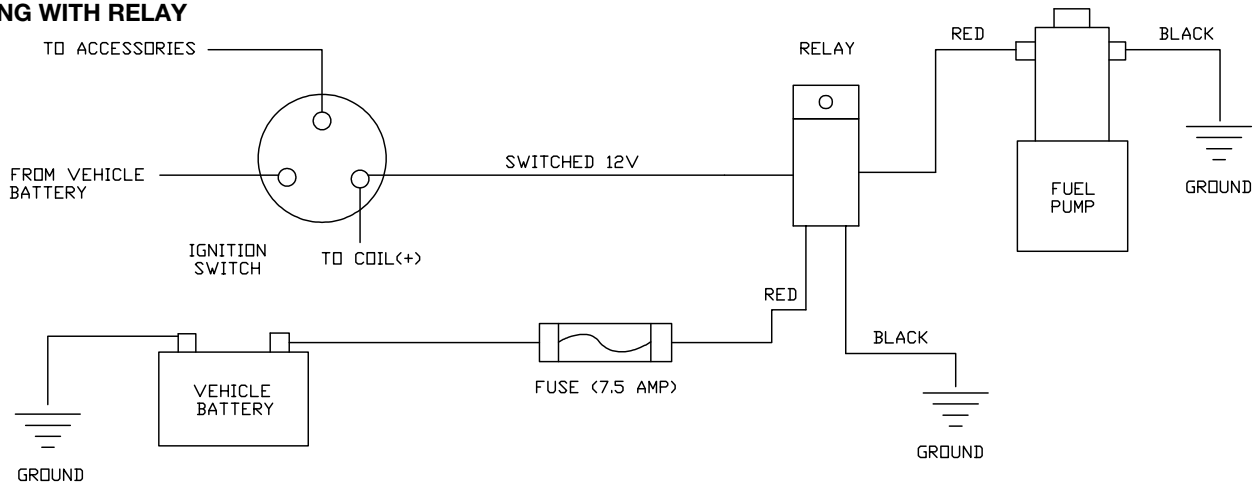

**FIGURE 4 - PREFERRED WIRING WITH RELAY AND OIL PRESSURE SAFETY SWITCH**

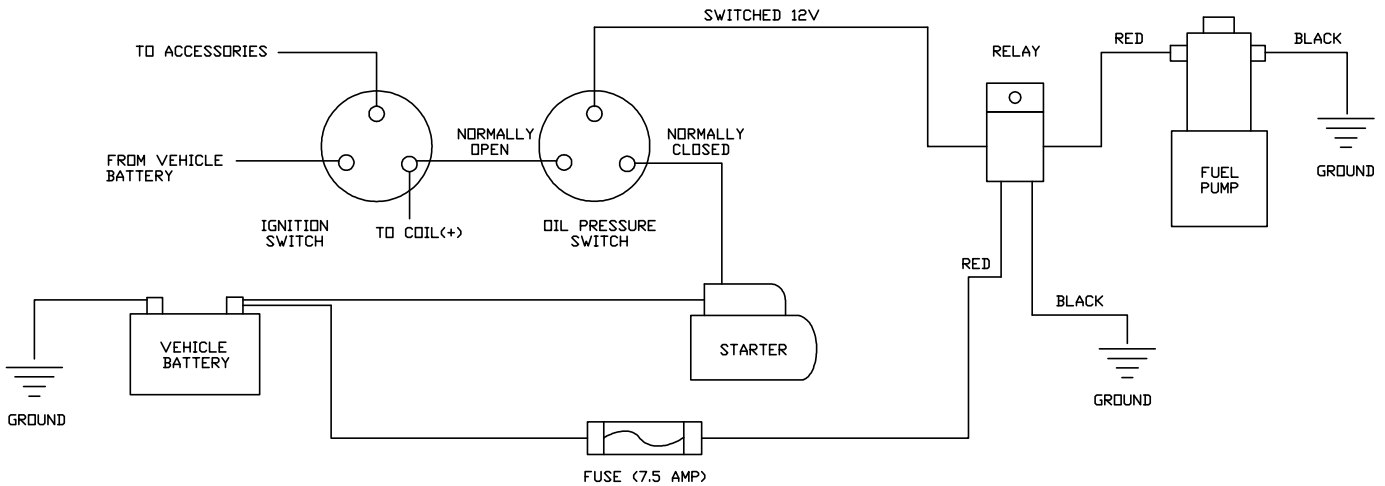

**MAINTENANCE – PUMP DISASSEMBLY**

If your pump fails to produce acceptable pressure, it may need cleaning. Follow the steps below to disassemble and clean your Mr. Gasket Electric Fuel Pump. Refer to Figure 5 while performing the following steps.

**Step 1**

Remove the pump from the vehicle and clean pump exterior. DO NOT immerse the unit in any liquid, as it could damage the pump, resulting in malfunction. Place the pump on a clean work surface.

**Step 2**

Remove the 5 bolts from the bottom of the pump, then the end plate and gasket. Next, remove the rotor stop plate. **IMPORTANT: Take note of the direction of the rotor vane chamfer for proper reassembly and pump performance. The chamfer should be on the trailing edge, facing out.**

**Step 3**

Remove the flame arrestor screen and observe the exact location of the screen. Remove the rotor vanes and rotor by turning over the pump.

**Step 4**

Unscrew the bypass screw and be careful as the bypass spring

behind it is biased outwardly. Once bypass spring is removed, take out bypass plunger.

**Step 5**

Clean the housing, rotor and vanes, plunger and bore with carburetor cleaner. Next, use compressed air to blow the housing and components dry.

**Step 6**

To reassemble your Mr. Gasket Electric Fuel Pump, first install the rotor, and then the vanes in the correct direction (see Step 2). The vanes should slide easily into the rotor slots. Then place the rotor stop plate over the rotor. Next, install the screen ensuring that it is secured behind the screen stop. Install the gasket and end plate making sure the gasket is positioned in the housing recessed cavity. Next, install the plunger, making sure it slides freely in the bore. Then install the spring and plug with seal. Finally, install the 5 bolts into the bottom of the pump.

**Step 7**

Install the fuel pump on your vehicle. Start the engine and verify there are no leaks.

**Step 8**

Verify there are no leaks after running engine.

**FIGURE 5  
PUMP DISSASSEMBLY**

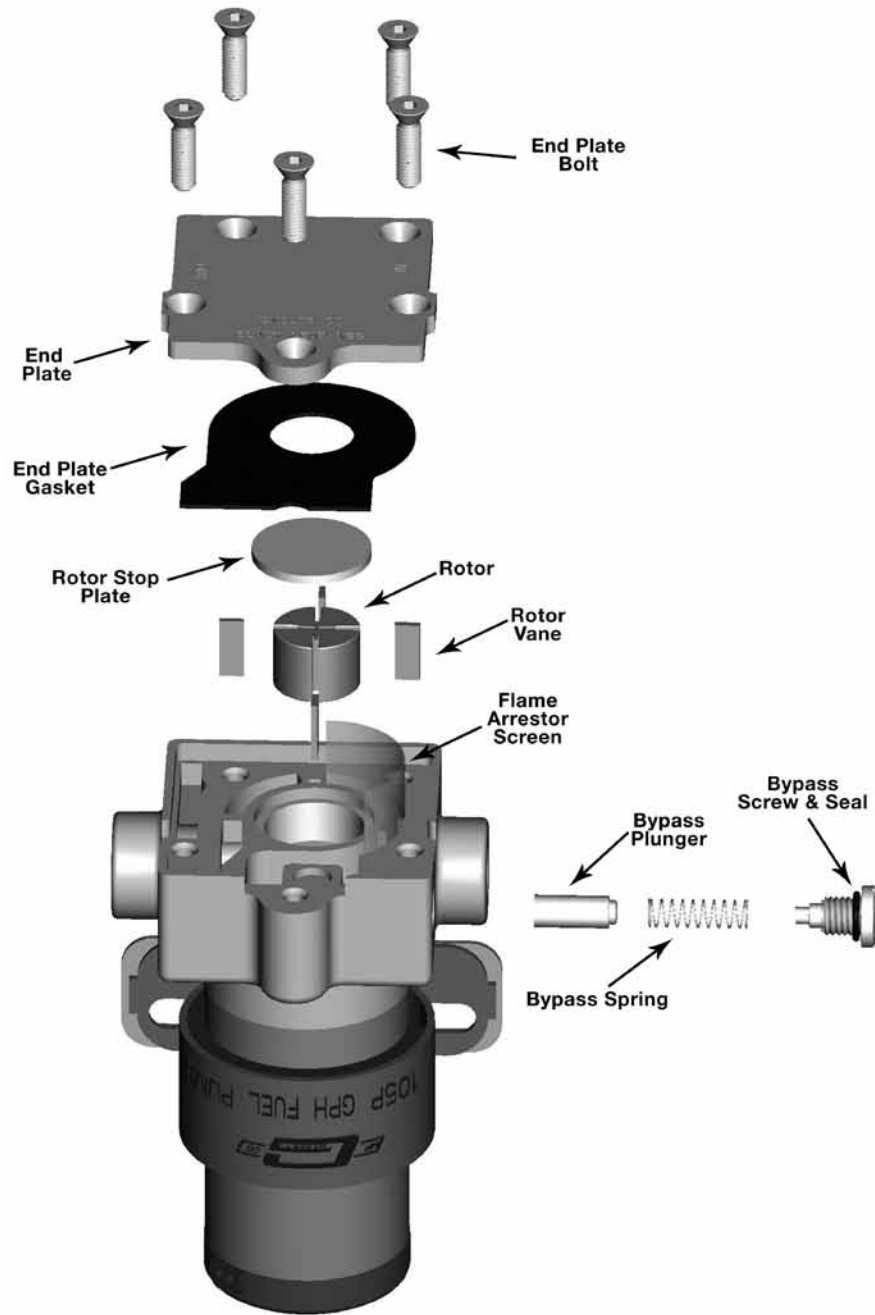

**TROUBLE SHOOTING**

**BOUNCING OR ERRATIC FUEL PRESSURE**

- Make sure bypass plunger slides freely in bore. If not, remove and clean plunger and bore with carburetor cleaner.
- Install a return style fuel pressure regulator if one is not already installed.
- Check for and remove any unnecessary restrictions in hoses as well as excessive fittings.
- Install a fuel return line that is one size larger than the feed line.
- Confirm the fuel return line pressure is free flowing back to the fuel tank with less than 2 lbs. of pressure.

**PUMP IS LOUD OR MAKING EXCESSIVE NOISE**

- There may be a leak you cannot see or smell. Double check all the fittings and hoses.

**QUESTIONS**

Please call our Tech Support line at 1-216-688-8300, M – F, 9 – 5 EST. Please have the part number on hand when you call.



MR. GASKET IS A TRADEMARK OF PRESTOLITE PERFORMANCE  
10601 MEMPHIS AVE #12, CLEVELAND, OH 44144  
216.688.8300 FAX 216.688.8306

FORM (Rev C) 95105130  
01/13